

SIDE VIEW
(PARTIAL SECTION)

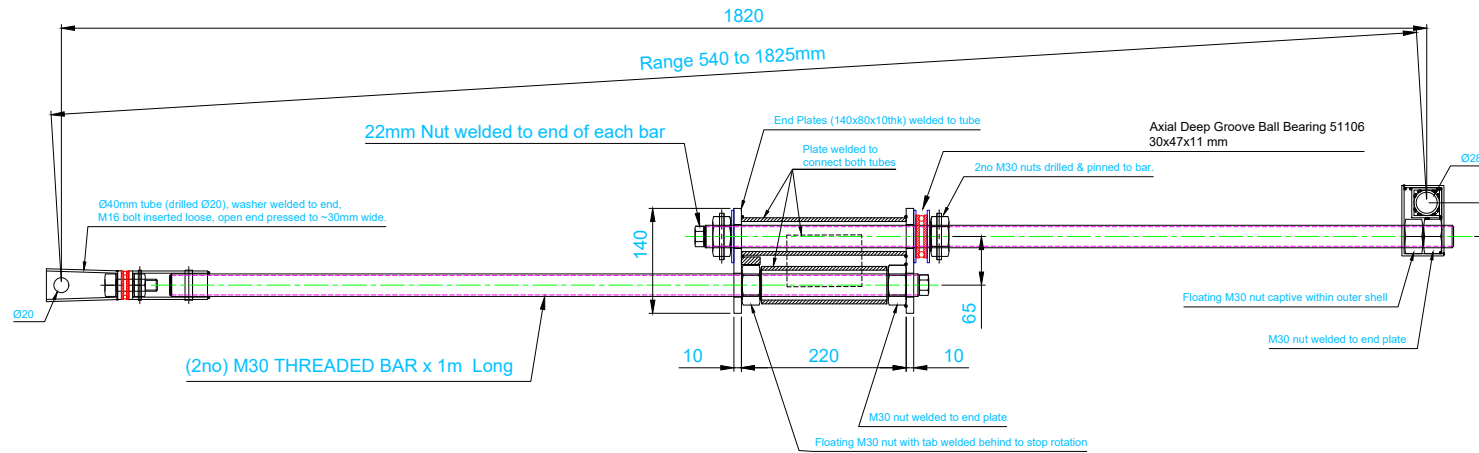

PLAN VIEW

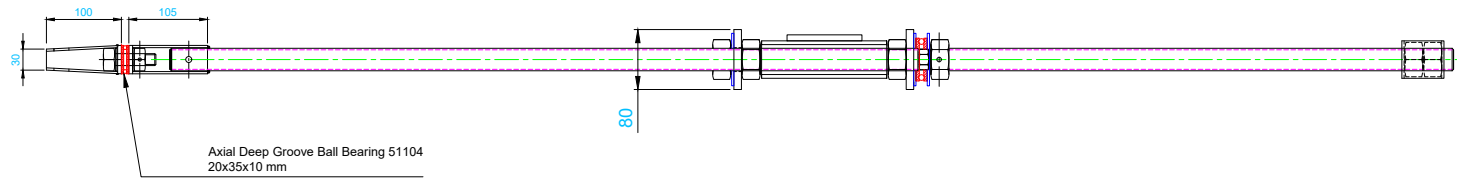

SIDE VIEW (CLOSED POSITION)

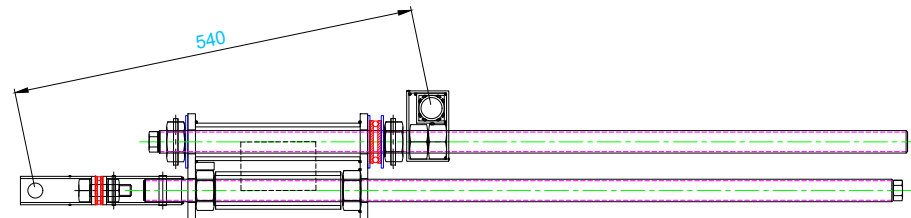

SBU CAB LIFT MECHANISM

DRAWN BY : CG
ALL DIMS IN mm
DATE :15-05-20
SCALE 1:1 on A4

Note : This drawing is provided in good faith and offered as a guide only, dimensioning and weld details are not complete. The drawing owner accepts no responsibility around operation of the mechanism. Fabrication and operation should only be completed by a suitably qualified / competent person. The mechanism should be used in conjunction with a check strap to prevent over extension and a chock to prevent collapse in raised position.